

SWi12/14TM SWi20/25TE SWi20/25TI

FLANGE
SPREADING
WEDGES



CONTENTS

1.	INTRODUCTION
2.	TOOL SAFETY
2.1	GENERAL SAFETY
2.2	PERSONNEL COMPETENCY
2.3	DISCLAIMER
2.4	DEFINITION OF TERMS
2.5	HAZARDS
3.	GENERAL SPREADING WEDGE TOOL OPERATION
3.1	GENERAL GUIDANCE
3.2	FLANGE SPREADING
3.3	FLANGE WORK
3.4	FLANGE CLOSURE
3.5	SAFETY BLOCKS
3.6	STEPPED BLOCKS
3.7	HANDLE
3.8	LANYARD
3.9	STEP DIMENSIONS & SPREADING DISTANCES
4.	TOOL MAINTENANCE
4.1	INSPECTION
4.2	CLEANING
4.3	MAINTENANCE
4.4	LUBRICATION
4.5	STORAGE & TRANSPORTATION
4.6	OPERATING CONDITIONS
4.7	SUB-SEA USAGE
5.	SWi12/14TM
5.1	TOOL CAPABILITIES
5.2	TOOL FUNCTION
5.3	KIT CONTENTS
5.4	DIMENSIONS
6.	SWi20/25TI
6.1	TOOL CAPABILITIES
6.2	TOOL FUNCTION
6.3	KIT CONTENTS
6.4	DIMENSIONS
7.	SWi20/25TE
7.1	TOOL CAPABILITIES
7.2	TOOL FUNCTION
7.3	KIT CONTENTS
7.4	DIMENSIONS
8.	TROUBLESHOOTING
8.1	SWi GENERAL TROUBLESHOOTING
8.2	SWi12/14TM TROUBLESHOOTING
8.1	SWi20/25TI TROUBLESHOOTING
8.2	SWi20/25TE TROUBLESHOOTING
9.	REGULATORY INFORMATION
9.1	REGISTERED HEAD OFFICE
9.2	APPLICABLE PATENT NUMBERS
10.	PARTS LISTS & SERVICE KITS

29/08/14

1.

INTRODUCTION

The Equalizer™ SWi Innovative Range of Flange Spreading Wedge tools has been developed to assist in the spreading of all flange joint types with a minimum access gap of 6.0mm (0.24”). The tools can be used during pipework construction, commissioning or during routine maintenance.

The SWi tools have less moving parts and no finger pinch points. The tools have been developed to increase the spreading distance on each step while gaining easier access between any remaining stud-bolts within the flange joint. The tools provide a much higher spreading force than the existing SW flange spreading tools. The SWi tools are supplied with a swivel handle, safety lanyard and stepped block attachment as standard.



It is essential that the user familiarises themselves with the contents of this manual prior to using the tool.

This manual contains information for the following tools:

- SWi12/14TM Mechanical Flange Spreading Wedge
- SWi20/25TI Integral Hydraulic Flange Spreading Wedge
- SWi20/25TE External Hydraulic Flange Spreading Wedge

2.

TOOL SAFETY

2.1

GENERAL SAFETY

These instructions cover the safe operation and maintenance of THE EQUALIZER **SWi12/14TM**, **SWi20/25TE** and **SWi20/25TI** FLANGE SPREADING WEDGE tools. The use of these tools should be as part of a broader task-based risk assessment, which should be carried out by the operation supervisor or other competent person.

Failure to comply with the safety information contained within this manual could result in personal injury or equipment damage. Read all instructions, warnings and cautions carefully, and follow all safety precautions.

The safety of the operator, any assisting personnel and the general public is of paramount importance. Always work in accordance with applicable national, local, site & company-wide safety procedures.

2.2

PERSONNEL COMPETENCY

Only personnel deemed competent in the use of mechanical and hydraulic equipment should use these tools.

2.3

DISCLAIMER

Equalizer cannot be held responsible for injury or damage resulting from unsafe product use, lack of maintenance or incorrect product and/or system operation. If in doubt as to the safety precautions and applications, contact Equalizer using the contact details at the back of this manual.

2.4

DEFINITION OF TERMS

A CAUTION is used to indicate correct operating or maintenance procedures and practices to prevent damage to, or destruction of equipment or other property.

A WARNING indicates a potential danger that requires correct procedures or practices to avoid personal injury.

A DANGER is only used when your action or lack of action may cause serious injury or even death.



DO: an illustration showing how the tool should be used.



DON'T: an illustration showing an incorrect way to use a tool.

2.5

HAZARDS



WARNING: ensure all hydraulic components are rated to a safe working pressure of 700bar (10,000psi).



WARNING: Do not overload equipment. The risk of hydraulic overloading can be minimised by using the Equalizer Hand Pump, which has a factory-set safety valve preventing the safe working pressure being exceeded.

If alternative hydraulic pumps are used, ensure that there are adequate systems to limit the the working pressure to 700 bar (10,000 psi).



CAUTION: ensure components are protected from external sources of damage, such as excessive heat, flame, moving machine parts, sharp edges and corrosive chemicals.



CAUTION: Take care to avoid sharp bends and kinks in hydraulic hoses. Bends and kinks can cause severe back-up pressure and cause hose failure. Protect hoses from dropped objects; a sharp impact may cause internal damage to hose wire strands. Protect hoses from crush

risks, such as heavy objects or vehicles; crush damage can cause hose failure.



WARNING: Applying pressure to a damaged hose may cause it to rupture.



WARNING: Immediately replace worn or damaged parts. Use only genuine Equalizer parts from approved distributors or service centres. Equalizer parts have been engineered and manufactured to be fit-for-purpose.



DANGER: To minimise risk of personal injury keep hands and feet away from the tool and workpiece during operation.



WARNING: Always wear suitable clothing and Personal Protective Equipment (PPE). Do not handle pressurised hoses; escaping oil under pressure can penetrate the skin, causing serious injury. Seek medical attention immediately if oil penetration is suspected.



WARNING: Only pressurize complete and fully connected hydraulic systems. Do not pressurize systems that contain unconnected couplers.



CAUTION: Do not lift hydraulic equipment by the hoses or couplers. Use only the designated carrying handles.



CAUTION: Lubricate tools as directed in this manual prior to operation. Use only approved lubricants of high quality, following the lubricant manufacturers instructions.



CAUTION: Only use the designated anchor point for fixing the lanyard. Do not attach the lanyard to the plastic handle.



DANGER: Care should be taken when using the lanyard to avoid entanglement with body parts.

3.

SWi SPREADING WEDGE TOOL OPERATION

3.1

GENERAL GUIDANCE

Before attaching the tool ensure at least two flange bolts remain in place. These should be 180 degrees apart with their nuts loosened sufficiently to enable flange work to be carried out. Leaving these bolts in place will help to reduce unwanted lateral flange movement during flange spreading.



Prior to spreading, an assesment should be carried out to determine the most appropriate positioning of the tools around the joint. A minimum of 2 tools should always be used.



Determine the flange joint access gap - a minimum access gap of 6 mm (0.24") is required for the SWi tools. The access gap is the clearance between the surfaces onto which the wedge will apply its spreading force.

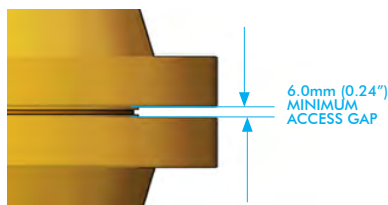

Place the tool into the access gap, with the full width of the selected step fully inserted up to the heel.

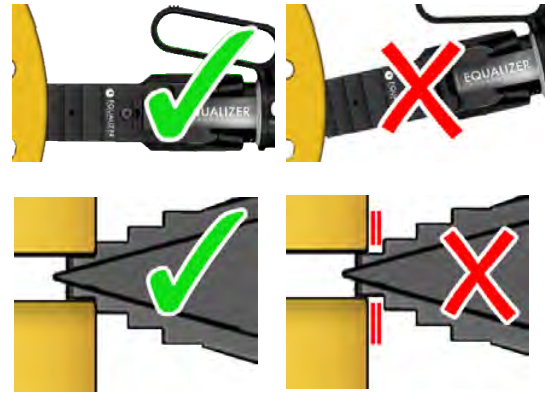

3.2

FLANGE SPREADING

Spread the flanges apart by actuating the tool. Consult the relevant section of the manual for tool-specific instructions on how to actuate each tool.

Once the joint has been opened to the desired distance, or if the tool has reached its maximum travel, insert the Safety Blocks into the flange joint.

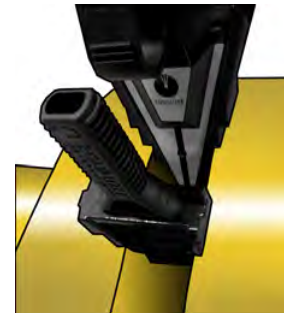

Ensure the full width of the selected Safety Block step is fully inserted before gradually retracting the tool until the flange load has been applied to them.

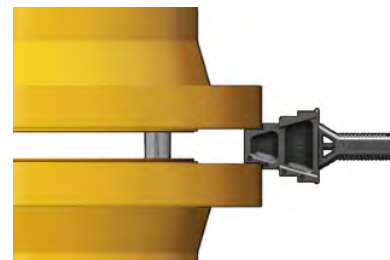

The wedges can then be retracted fully and inserted again, using the next step. In this way the flange joint can be iteratively opened further until the required spread is reached.

3.3 FLANGE WORK



Do not rely upon hydraulic systems for supporting the access gap during flange work. Do not allow fingers, hands or other body parts into the space created between the flanges.

3.4 FLANGE CLOSURE

Allow the flanges to return to their closed position by gradually retracting the tool. Consult the relevant section of the manual for tool-specific instructions on how to retract each tool. Before the tool has fully retracted, insert the Safety Blocks into the flange joint. Ensure the full breadth of the selected Safety Block step is fully inserted, before gradually retracting the tool until the flange load has been applied to them.

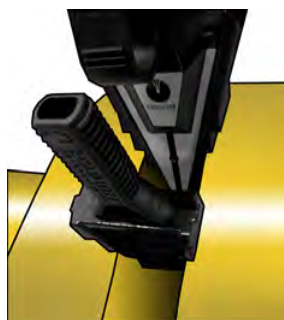

To use the next smallest step, actuate the wedges to around 75% prior to inserting back into the joint. Place the tool in the gap and actuate enough to relieve the load on the Safety Blocks. In this way the flange joint can be progressively closed.

As the flange approaches its fully closed position, support the tool to avoid it dropping out of the joint. Ensure that care is taken to prevent objects being dropped. Dropped objects pose a risk of personal injury or equipment damage.

3.5 SAFETY BLOCKS

Each tool is supplied with a set of 2 Safety Blocks. The Safety Blocks have been designed with steps that match the spreading distance of the SWi tools.



3.6 STEPPED BLOCKS

The SWi Range of Flange Spreader tools are supplied as standard with a pair of Stepped Blocks. These can be fixed to the jaws (individually or in pairs) to increase the effective jaw thickness and therefore the maximum spreading distance.

Use of the Stepped Blocks also enables the SWi Flange Spreaders to be used in a joint with a larger access gap.

Wedge protrusion can be minimised by the use of Stepped Blocks, reducing the penetration into the joint. This enables, for example, spectacle blinds to be changed.

Attach the stepped block to the tool using the M6 counter-sunk screw. Use the hex-key supplied to tighten the screw into the threaded hole in the jaw of the tool. Repeat for second Stepped Block to further increase the effective jaw thickness if required.

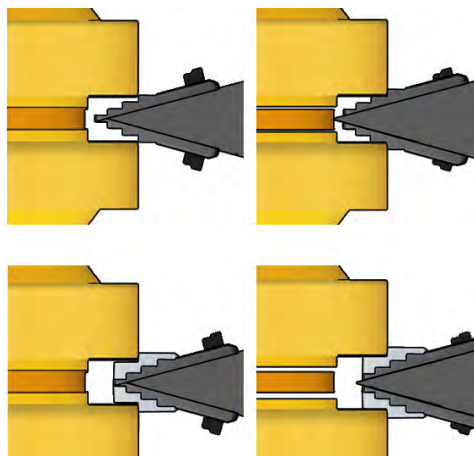

To remove the Stepped Blocks unscrew the M6 counter-sunk screw. Do not force the screw out of the Stepped Block, it is deliberately retained to prevent it becoming misplaced.

Use the tool as per the Tool Operation instructions. Ensure that there is a minimum hold of 15mm (0.59") and that the full width of the block is used.

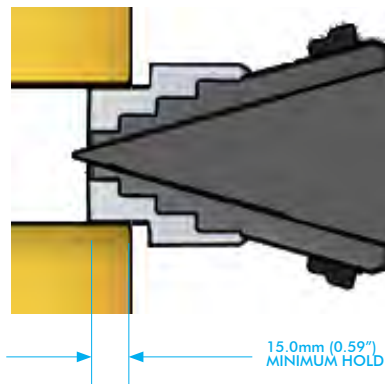

3.7 HANDLE

The handle can be swivelled around the central axis of the tool, to improve access to the Flange and allow the tool to be easily held in the vertical or horizontal orientation.

If the tool is being used in an application where access space is very limited, the handle can be removed temporarily. Unclip the spiral ring and remove the anchor point and handle. Special caution should be exercised when working with a tool in this configuration. Replace the handle immediately following the task.

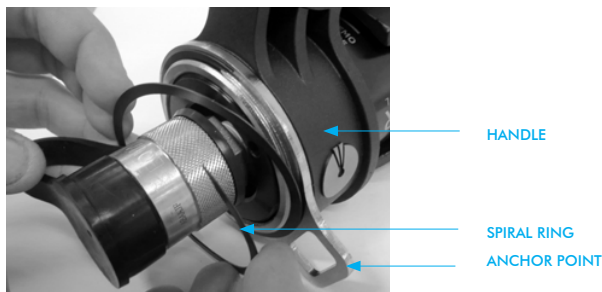

3.8 LANYARD

The SWi tools are supplied with a secure anchor point and a lanyard. The lanyard should be used to minimise the risks associated with the tool dropping.

Attach one end of the lanyard to the tool using the supplied shackle. The other end of the lanyard should be fixed to a secure point close to the work-site using an appropriate shackle.

Avoid using the lanyard as a means for picking up or carrying the tool. Do not fix the lanyard to the handle.

The anchor point and lanyard have been engineered to safely sustain a drop over the full lanyard length. It is recommended that all parts are inspected following a drop incident, as damage may compromise the safety of the tool.



CAUTION: Only use the designated anchor point for fixing the lanyard. Do not attach the lanyard to the plastic handle.



DANGER: Care should be taken when using the lanyard to avoid entanglement with body parts.

3.9 STEP DIMENSIONS & SPREADING DISTANCES

SAFETY BLOCK DIMENSIONS

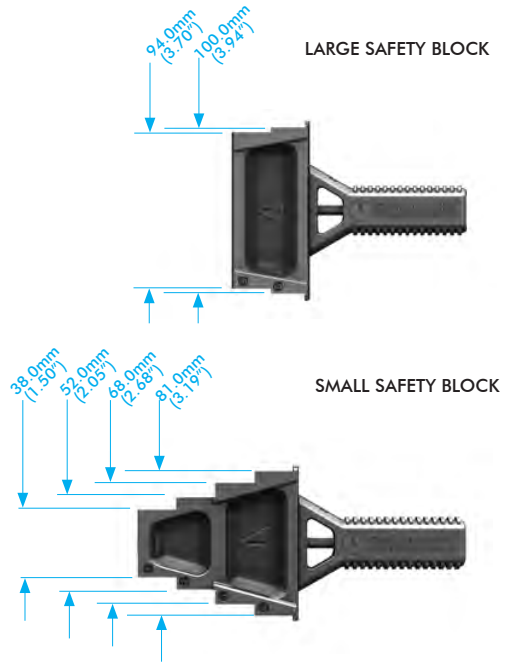

JAW DIMENSIONS (WITHOUT STEPPED BLOCKS ATTACHED)

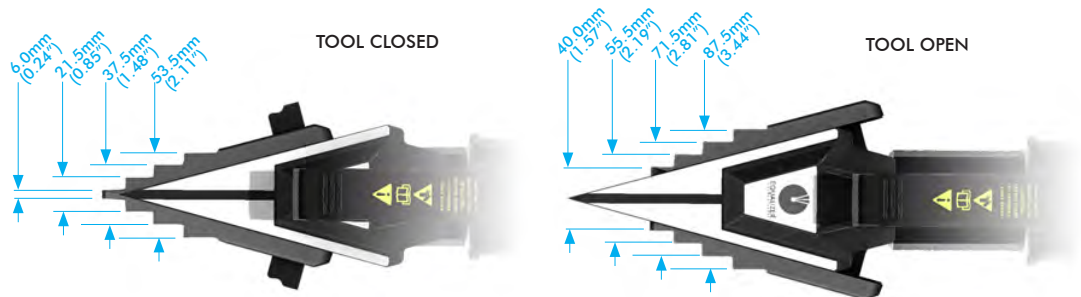

JAW DIMENSIONS (WITH STEPPED BLOCKS ATTACHED)

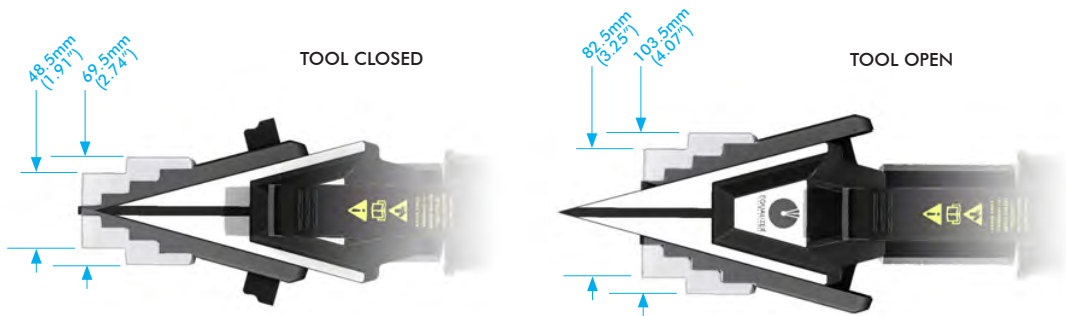

4.

TOOL MAINTENANCE

4.1

INSPECTION

A thorough inspection should be carried out prior to usage, storage or transportation to ensure the completeness and condition of the tool.

Inspection should include:

- visual inspection of the outer parts of the tool, checking for obvious damage, degradation or missing parts
- visual inspection of the wedge-tip (requiring tool actuation or jaw removal). Damage to the wedge-tip is indicative of tool over-load.

Cleaning and servicing should be undertaken as required prior to the tool being used, stored or transported.

4.2

CLEANING

To lightly clean the tool, wipe gently with a damp cloth.

If more thorough cleaning is required (for example following immersion in water) carry out the following cleaning procedure:

- strip the tool down, observing the schematics in section 10.
- clean the components using detergent, following the manufacturer's guidelines
- rinse the components to remove traces of detergent
- dry the components thoroughly

Inspect, service and lubricate the tool immediately after the cleaning process.

4.3

SERVICING

Replace missing worn or damaged parts. Use only genuine Equalizer parts from approved distributors or service centres. Equalizer parts have been engineered and manufactured to be fit-for-purpose.

Grease all moving parts by following the Lubrication Procedure prior to usage, storage or transportation.

Do not exceed 5.0N.m (3.68ft.lb) of torque when tightening the Jaw retaining screws. The jaws have been engineered to have a small degree of movement when correctly tightened.

If topping up or replacing hydraulic oil as part of a service, use only premium quality hydraulic oil of the grade 15cSt.

4.4

LUBRICATION PROCEDURE

Apply grease following cleaning and servicing, prior to usage, storage or transportation. Never assemble and leave a tool without following the greasing procedure as degradation or damage may occur.

Use only high pressure molybdenum disulphide grease.

Remove the jaws as per the disassembly instructions.

Apply grease liberally to the following areas:

- the large flat surface on the underside of the jaws
- the internal flat surfaces in the square cut-out in the jaws

4.5

STORAGE & TRANSPORTATION

Equalizer tools should be stored in a cool dry place. Tools should always be cleaned, serviced and lubricated prior to storage. Ensure that tools are stored in their designated packing cases.

4.6

OPERATING CONDITIONS

GREASE LIMITATIONS:

Minimum Temperature:	-5°C (23°F)
Maximum Temperature:	40°C (104°F)

MECHANICAL TOOLS:

Minimum Jaw Contact Temperature:	-30°C (-22°F)
Maximum Jaw Contact Temperature:	150°C (302°F)

HYDRAULIC TOOLS:

Minimum Jaw Contact Temperature:	-30°C (-22°F)
Maximum Jaw Contact Temperature:	70°C (158°F)

4.7

SUB-SEA USAGE

The Equalizer range of HP hydraulic hand pumps are fitted with a sealed-bladder type reservoir system that allows for sub-sea operation.

Using SWi12/14TM Sub-Sea

The SWi20/25TM is actuated mechanically and can be used sub-sea providing the following actions are taken:

- The tool is actuated via the torque-wrench by a diver.
- The tool and pump are stripped-down, cleaned and lubricated immediately to minimise corrosion.

Using SWi20/25TI Sub-Sea

The SWi20/25TI is actuated by means of single-acting spring-return hydraulic cylinder and can be used sub-sea providing the following actions are taken:

- The pump release valve is fully opened and remains open until the tool has descended to the working depth. This will allow the pressure to equalise.
- The tool is actuated via the hand pump by a diver.
- Upon completion of works the release valve is left in the fully-open position until the tool has ascended to the surface.
- The tool and pump are stripped-down, cleaned and lubricated immediately to minimise corrosion.

Using SWi20/25TE Sub-Sea

The SWi20/25TE is actuated by means of single-acting spring-return hydraulic cylinder and can be used sub-sea providing the following actions are taken:

- The gauge and manifold are removed from the Equalizer HP350S/D hydraulic hand-pump and the coupler is fitted directly to the pump outlet (tools in this configuration can be requested from Equalizer).
- The tool is connected to the Equalizer HP350S/D pump whilst still top-side.
- The pump release valve is fully opened and remains open until the tool has descended to the working depth. This will allow the pressure to equalise.
- The tool is actuated via the hand pump by a diver.
- Upon completion of works the release valve is left in the fully-open position until the tool has ascended to the surface.
- The tool and pump are stripped-down, cleaned and lubricated immediately to minimise corrosion.

Please note that a sub-sea SWi20/25TE tool cannot be operated from top-side by use of a down-line. The return springs in the hydraulic cylinders do not have sufficient force to close the tool if used with a down-line from a top-side pump, therefore the standard hydraulic tools will not function correctly and may jam in place if used in this configuration.

5.

SWi12/14TM

MECHANICAL FLANGE SPREADING WEDGE

The SWi12/14TM Spreading Wedge uses mechanical torque to advance the wedge and spread the jaws.



5.1

SWi12/14TM TOOL CAPABILITIES

SPREADING FORCE

Maximum SWL torque of 175N.m (130ft.lb) will generate 12T (120kN) spreading force on the 1st step and 14T (140kN) spreading force on the 4th step.

5.2

SWi12/14TM TOOL FUNCTION

MECHANICAL TOOL OPERATION

The SWi12/14TM Spreading Wedge uses mechanical torque to advance the wedge and spread the jaws. The torque is applied using the supplied Torque Wrench, enabling accurate control of the force applied.



TORQUE WRENCH USAGE

Holding the Torque Wrench in one hand, unlock the knurled handle by turning the locking knob anti-clockwise.

Select the torque setting by turning the knurled handle until the required torque value is indicated.

For example, to set the Torque Wrench to 46Nm: turn the knurled handle until the 0 on the fine scale aligns with 40Nm on base scale; now turn slightly further until the 6 on the fine scale aligns with the central line.

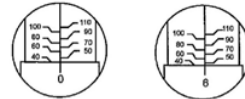

Setting an imperial torque (in ft.lb) is done in exactly the same way.

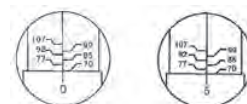

Lock the handle by turning the locking knob clockwise.

Install the supplied socket onto the Torque Wrench and attach to the tool.

Slowly and smoothly pull the handle, gradually applying more force until you feel or hear the Torque Wrench click, indicating that the selected torque has been achieved. Do not continue to apply force after the Torque Wrench has clicked. Special care should be taken when using low torque settings.

TORQUE WRENCH CARE

Prior to storing the Torque Wrench, and between use, leave the Torque Wrench with its lowest torque setting selected.

To clean the Torque Wrench, wipe gently with a damp cloth. Avoid using any detergent or solvent as this may detrimentally affect the factory-fitted internal lubrication of the mechanism.

ACTUATING THE SWi12/14TM

Follow the SWi Spreading Wedge Tool Operation instructions, using the following instructions to actuate the SWi12/14TM tool in particular:

Actuate the tool by manually applying force to the torque wrench in the clockwise direction (see Torque Wrench Usage). Gradually increase the torque setting of the Torque Wrench over several steps, for example 30Nm (or 20ft.lb) each time. Do not exceed the maximum SWL torque of 175N.m (130ft.lb).

When using multiple tools, ensure that the torque settings of all wrenches correspond to keep the spreading force balanced.

RETRACTING THE SWi12/14TM

Retract the tool by manually applying force to the torque wrench in the anti-clockwise direction. When using multiple tools, work around all wrenches to keep the spreading force balanced as the gap is closed.

5.3

SWi12/14TM KIT CONTENTS

STANDARD KIT

Product Code: SWi1214TMSTDSPB

- 1 x SWi12/14TM Mechanical Flange Spreader Wedgehead
- 1 x Mechanical Cylinder
- 1 x Torque Wrench with 22mm Socket
- 1 x Set of Safety Blocks
- 1 x Pair of Stepped Blocks
- 1 x Lanyard
- 1 x Hex Key
- 1 x Instruction Manual
- 1 x Plastic Carry Case



580mm x 330mm x 165mm (22.8" x 13.0" x 6.5")

Gross kit weight: 13.0kg (28.6lb)
 Tool only weight: 6.2kg (13.7lb)

5.4

SWi12/14TM DIMENSIONS

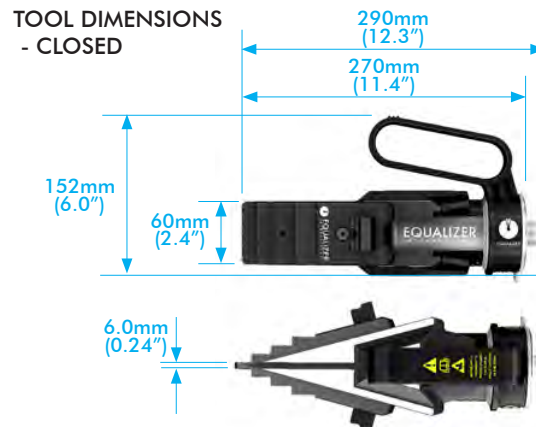

6.

SWi20/25TI

INTEGRAL HYDRAULIC FLANGE SPREADING WEDGE

The SWi20/25TI Spreading Wedge uses an integral hydraulic cylinder to advance the wedge and spread the jaws.



6.1

SWi20/25TI TOOL CAPABILITIES

SPREADING FORCE

With the maximum hydraulic pressure of 700bar (10,000psi) applied, the tool can apply 20T (200kN) spreading force on the 1st step, up to 24T (240kN) spreading force on the 4th step.

SPREADING GAP (SEE SECTION 3.9)

Using only the 1st step, the tool can spread from 6.0mm to 40.0mm (0.24" - 1.6").

Using all 4 steps, but without the stepped blocks, the tool can spread from 6.0mm to 87.5mm (0.24" - 3.4").

Using both steps on the stepped blocks, the tool can spread 48.5mm – 103.5mm (1.9" - 4.1").

6.2

SWi20/25TI TOOL FUNCTION

HYDRAULIC TOOL OPERATION

Prior to operation, ensure the air-vent in the integral hand pump is not obstructed. Any obstruction in the air-vent can cause a vacuum in the system which can limit the cylinder's travel.

The SWi20/25TI Spreading Wedge uses a hydraulic cylinder to advance the wedge and spread the jaws. The hydraulic pressure is applied using the integrated hand pump, enabling accurate control of the force applied.

The integral hand pump has a control lever which allows the user to select advance (+) or retract (-).



ACTUATING THE SWi20/25TI

Follow the SWi Spreading Wedge Tool Operation instructions, using the following instructions to actuate the SWi20/25TI tool in particular:

When advance (+) is selected, pumping the handle will advance the cylinder and spread the jaws.



RETRACTING THE SWi20/25TI

Selecting retract (-) will depressurise the cylinder and cause it to retract under the force of its internal spring. The handle does not need to be pumped to retract the tool.

When using multiple tools, exercise caution while retracting to keep the spreading force balanced as the gap is closed.

AIR RELIEF INSTRUCTIONS

In the event of air build-up within the cylinder-pump subassembly, the following procedure should be executed:

Select advance (+), and pump the handle to extend the piston around 30mm (1.2"). Remove the Oil Fill Screw using an appropriate hex key, ensuring the tool is on its side with the Oil Fill facing upwards (top photo).



Replenish any missing hydraulic oil by pouring into the Oil Fill hole until excess spills over (middle photo).

Sit the tool with the wedge facing uphill (and the open Oil Fill hole still facing upwards) on a gentle slope, around 30 degrees from horizontal.

Very slowly move the selector from advance (+) to retract (-), and wait for the tool to fully retract (lower photo).

Replace the Oil Fill Screw.

Repeat this procedure 3 times.

6.3

SWi20/25TI KIT CONTENTS

STANDARD KIT

Product Code: SWi2025TISTDSPB



- 1 x SWi20/25TI Flange Spreader Wedgehead
- 1 x 10,000psi (700bar) Integral Hydraulic Pump/Cylinder
- 1 x Set of Safety Blocks
- 1 x Pair of Stepped Blocks
- 1 x Lanyard
- 1 x Hex Key
- 1 x Carry-Strap
- 1 x Instruction Manual
- 1 x Carry Case

580mm x 330mm x 165mm (22.8" x 13.0" x 6.5")

Gross kit Weight 13.8kg (30.4lb)
 Tool only weight: 8.5kg (18.7lb)

6.4

SWi20/25TI DIMENSIONS

TOOL DIMENSIONS
 - CLOSED

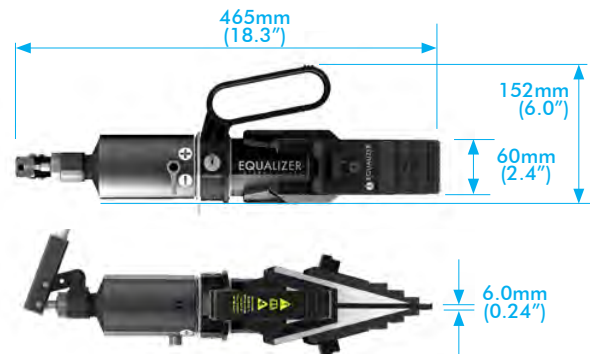

7.

SWi20/25TE

HYDRAULIC FLANGE SPREADING WEDGE

The SWi20/25TE Spreading Wedge uses an external hydraulic pump to drive the cylinder to advance the wedge and spread the jaws.



7.1

SWi20/25TE TOOL CAPABILITIES

SPREADING FORCE

With 700bar (10,000psi) of hydraulic pressure applied, the tool can apply 20T (200kN) spreading force on the 1st step, up to 24T (240kN) spreading force on the 4th step.

SPREADING GAP (SEE SECTION 3.9)

Using only the 1st step, the tool can spread from 6.0mm to 40.0mm (0.24" - 1.6").

Using all 4 steps, but without the stepped blocks, the tool can spread from 6.0mm to 87.5mm (0.24" - 3.4").

Using both steps on the stepped blocks, the tool can spread 48.5mm – 103.5mm (1.9" - 4.1").

7.2

SWi20/25TE TOOL FUNCTION

HYDRAULIC TOOL OPERATION

The SWi20/25TE Spreading Wedge uses a hydraulic cylinder to advance the wedge and spread the jaws. The hydraulic pressure is applied using an external hand pump, enabling accurate control of the force applied.

HAND PUMP OPERATION

Consult the Instruction Manual for the Equalizer HP Hand-Pump supplied in the kit.

ACTUATING THE SWi20/25TE

Follow the SWi Spreading Wedge Tool Operation instructions, using the following instructions to actuate the SWi20/25TE tool in particular:

When the Hand-Pump release valve is closed, pumping the Hand-Pump handle will advance the cylinder and spread the jaws.

When using multiple tools, ensure that the spread of all tools correspond to keep the spreading force balanced.

The Maxi-kit includes a twin-port hand pump which can be used to actuate two tools simultaneously.

RETRACTING THE SWi20/25TE

Opening the release valve will depressurise the cylinder and cause it to retract under the force of its internal spring. The handle does not need to be pumped to retract the tool.

When using multiple tools, exercise caution while retracting to keep the spreading force balanced as the gap is closed.

AIR-LOCK RELIEF

If full pressure is not achieved an air-lock may be present in the hydraulic system. The following procedure can be executed to relieve any air-locks.

Connect the hand pump to the tool with the hydraulic hose. Close the release valve on the pump, and prime the pump until the hydraulic cylinder is fully extended and a small pressure is achieved.

With the hand pump elevated above the level of the tool, and the tool in an upright position, open the hand pump release valve causing any air that is within the system to be forced up through the pump and vented into the oil reservoir.

Repeat this process three further times to ensure that all air is removed from the system. The tool should now reach full working pressure

Disconnect the hand pump from the hydraulic hose, grip the baseplate of the hand pump body in a vice with the pump body vertical and the main handle at the top. Remove the four nuts holding the main handle and lift off. Grip the refilling plug with pliers and extract it by pulling and twisting simultaneously. Ensure the reservoir body is held down when removing the refilling plug as pulling up on the reservoir body will release the bladder within, and oil may spill out. Fill the reservoir to the top with a premium quality hydraulic oil of the grade 15 cSt. Reinsert the refilling plug, wipe away any oil, and reassemble by reversing the disassembly process.

7.3

SWi20/25TE KIT CONTENTS

MINI KIT

Product Code: SWi2025TEMIN

- 1 x SWi20/25TE Flange Spreader Wedgehead
- 1 x 10,000psi (700bar) Hydraulic Cylinder
- 1 x Set of Safety Blocks
- 1 x Pair of Stepped Blocks
- 1 x Hex Key
- 1 x Lanyard
- 1 x Instruction Manual
- 1 x Plastic Carry Case



580mm x 330mm x 165mm (22.8" x 13.0" x 6.5")

Gross kit Weight 11.6kg (25.6lb)
 Tool only weight: 6.4kg (14.1lb)

STANDARD KIT

Product Code: SWi2025TESTDSPB

- 1 x SWi20/25TE Flange Spreader Wedgehead
- 1 x 10,000psi (700bar) Hydraulic Cylinder
- 1 x 10,000psi (700bar) Hydraulic Hose, 2m (78.75") with 90 degree elbow
- 1 x 10,000psi (700bar) HP350S Sealed Hand Pump with Gauge
- 1 x Set of Safety Blocks
- 1 x Pair of Stepped Blocks
- 1 x Hex Key
- 1 x Lanyard
- 1 x Set of Instruction Manuals
- 1 x Plastic Carry Case



920mm x 500mm x 205mm (36.2" x 19.7" x 8.1")

Gross kit Weight 20.7kg (45.6lb)
 Tool only weight: 6.4kg (14.1lb)

MAXI KIT

Product Code: SWi2025TEMAXSPB

- 2 x SWi20/25TE Flange Spreader Wedgeheads
- 2 x 10,000psi (700bar) Hydraulic Cylinders
- 2 x 10,000psi (700bar) Hydraulic Hoses, 2m (78.75") with 90 degree elbow
- 1 x 10,000psi (700bar) HP550D Sealed Hand Pump with Gauges
- 2 x Sets of Safety Blocks
- 2 x Pairs of Stepped Blocks
- 2 x Hex Keys
- 2 x Lanyards
- 1 x Set of Instruction Manuals
- 1 x Plastic Carry Case



920mm x 500mm x 205mm (36.2" x 19.7" x 8.1")

Gross kit Weight 33.0kg (72.8lb)
 Tool only weight: 6.4kg (14.1lb)

7.4

SWi20/25TE DIMENSIONS

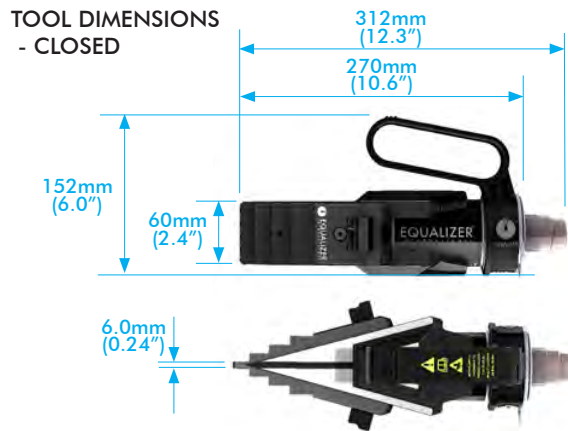

8.

TROUBLESHOOTING

8.1

SWi20/25TI TROUBLESHOOTING

THE WEDGE ADVANCES SOME OF THE WAY AND THEN STOPS PROGRESSING

POSSIBLE CAUSE:

The air-vent is obstructed by dirt or debris.

RECOMMENDED ACTION:

Carefully unblock the air-vent using a small blunt object.

THE WEDGE DOESN'T MOVE

POSSIBLE CAUSE:

There is an air-lock within the hydraulic system.

RECOMMENDED ACTION:

Select Retract (-) and prime pump to circulate oil around the system.

POSSIBLE CAUSE:

Insufficient oil in the hydraulic system.

RECOMMENDED ACTION:

Refill with clean oil and bleed the hydraulic system.

POSSIBLE CAUSE:

Retract (-) is selected.

RECOMMENDED ACTION:

Select Advance (+) and pump the handle.

POSSIBLE CAUSE:

Air has accumulated around pump inlet when used upside down.

RECOMMENDED ACTION:

Bleed any air from the hydraulic reservoir. Inspect the tool for oil leaks on the reservoir, possibly indicative of a perished bladder. Refer to an approved Equalizer

distributor for repair.

POSSIBLE CAUSE:

The inlet check-valve or intermediate valve ball has become stuck.

RECOMMENDED ACTION:

Dismantle the check valve, free and clean the valve balls. Refer to an approved Equalizer distributor for repair.

THE WEDGE MOVES AS INTENDED, BUT DOESN'T SEEM TO BE ACHIEVING FULL PRESSURE WHEN UNDER LOAD

POSSIBLE CAUSE:

Intermediate valve not seating / relief valve leaking.

RECOMMENDED ACTION:

Check cleanliness of valve ball. Re-seat using a hammer and punch. Refer to an approved Equalizer distributor for further instruction.

HYDRAULIC PRESSURE SLOWLY DIMINISHES AND THE PUMP HANDLE RISES

POSSIBLE CAUSE:

The outlet check valve is leaking.

RECOMMENDED ACTION:

Check cleanliness of valve ball. Re-seat using a hammer and punch. Refer to an approved Equalizer distributor for further instruction.

HYDRAULIC PRESSURE SLOWLY DIMINISHES AND THE PUMP HANDLE DOES NOT RISE

POSSIBLE CAUSE:

The release valve is leaking.

RECOMMENDED ACTION:

Refer to an approved Equalizer distributor for further instructions.

POSSIBLE CAUSE:

The piston seal is leaking.

RECOMMENDED ACTION:

Inspect the tool for oil leaks, possibly indicative of a perished seal or loose blanking plug. Refer to an approved Equalizer distributor for further instructions.

TOOL ACTUATION FEELS SOFT AND UNRESPONSIVE

POSSIBLE CAUSE:

There is air in the hydraulic system.

RECOMMENDED ACTION:

Bleed the hydraulic system. Refer to an approved Equalizer distributor for further instruction.

8.2**SWi20/25TE TROUBLESHOOTING****THE WEDGE IS ADVANCING BUT DOES NOT REACH FULL PRESSURE**

POSSIBLE CAUSE:

There is air in the hydraulic system.

RECOMMENDED ACTION:

Follow the Airlock Relief instructions.

9.

REGULATORY INFORMATION

9.1

REGISTERED HEAD OFFICE

EQUALIZER INTERNATIONAL LTD.
Equalizer House
Claymore Drive
Aberdeen
Scotland
AB23 8GD

9.2

APPLICABLE PATENT NUMBERS

The following list of Patents are applicable to EQUALIZER INTERNATIONAL LTD SWi12/14TM, SWi20/25TI and SWi20/25TE tools:

REGISTERED DESIGNS

- 002224980-0001
- 002224980-0002
- 002224980-0003
- 002224980-0004
- 84204
- 353180
- 256685
- 2L201330454407.8

REGISTERED PATENTS

- WO01/66191
- 1259293B
- 6880809
- WO98/47809
- 2328671B
- 219545
- 70630/98
- 316596
- 6267354
- 1012105B

10.

PARTS LISTS & SERVICE KITS

SWi12/14TM PARTS LIST

850000-01 REV.02

ITEM NO.	PART NO	DESCRIPTION	QTY.
1	830201-01	WEDGE	1
2	830202-01	WEDGE TIP	1
3	830400-01	HANDLE	1
4	830500-01	CAPTIVE FASTENER	2
5	830600-01	LUGS	1
6	830800-01	ANCHOR POINT	1
7	830313-01	SPIRAL RETAINING RING	1
8	850300-01	MECHANICAL CYLINDER	1
9	830100-01	SWI JAW - SOLD IN PAIRS	2
10	KIT 840140-01	RETAINING WASHER	2
11		M6 CSK HEX SCREW	3
12		WASHER (0.8MM)	2
13		M5 SCKT SET SCREW	1
14	KIT 840150-01	M6 GRUB SCREW	2
15		DECAL WEDGE LRG	2
16		DECAL WEDGE SML	2
17		DECAL TI PUMP (SURPLUS IN TE & TM)	1
18	ON REQUEST	DECAL TM CYLINDER WRAP	1

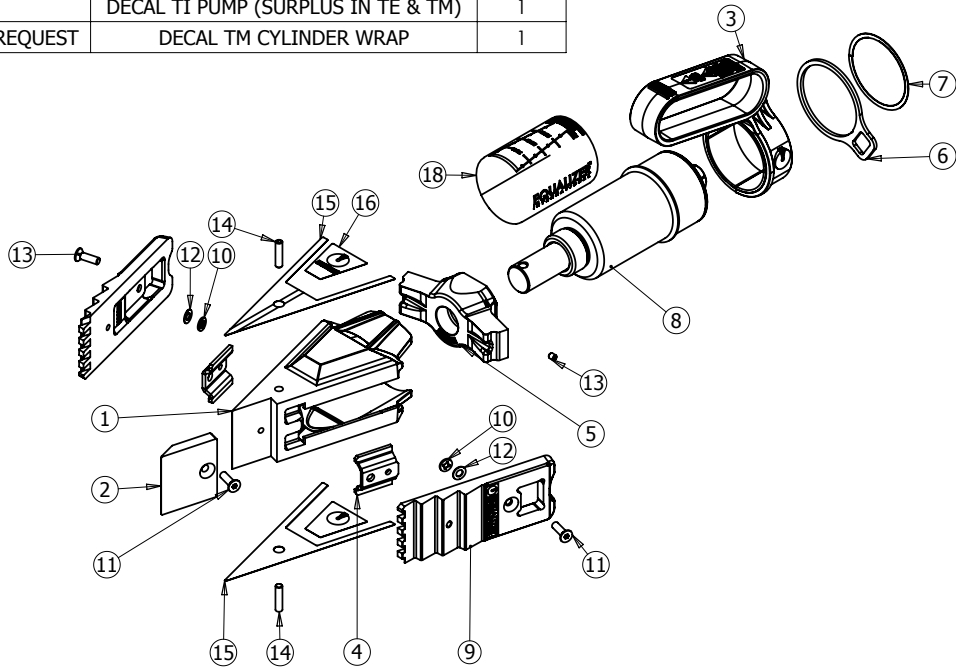

MECHANICAL CYLINDER PARTS LIST

850300-01 REV.03

ITEM NO.	PART NO	DESCRIPTION	QTY
1	850301-01	CYLINDER BASE	1
2	850302-01	DRIVE ROD	1
3	850303-01	CYL CAP	1
4	850304-01	PUSH ROD	1
5	850305-01	DRIVE HEX	1
6	850306-01	THREAD STOP	1
7	KIT 850110-01	THRUST WASHER	2
8		THRUST RACE	1
9		DOWEL PIN	1
10		M6 CSK HEX SCREW	1

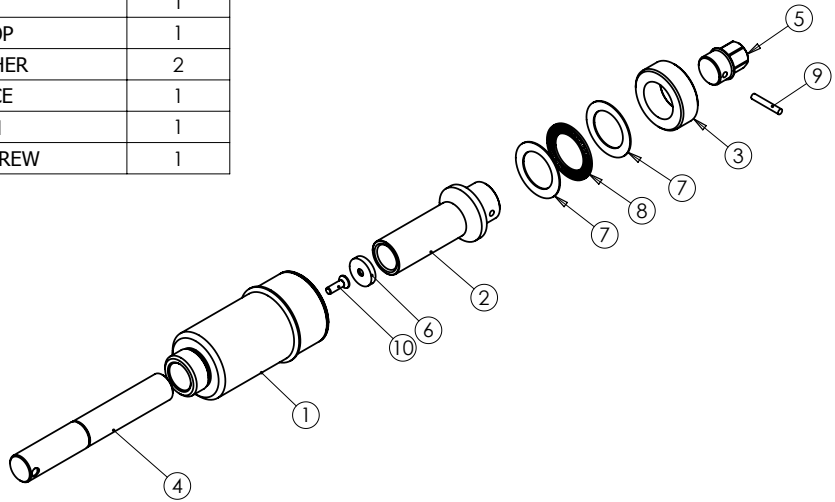

SWi20/25TI PARTS LIST

840000-01 REV.03

ITEM NO.	PART NO	DESCRIPTION	QTY
1	830201-01	WEDGE	1
2	830202-01	WEDGE TIP	1
3	840300-01	H.CYLINDER & PUMP TI ASSEMBLY	1
4	830400-01	HANDLE	1
5	830500-01	CAPTIVE FASTENER	2
6	830600-01	LUGS	1
7	830800-01	ANCHOR POINT	1
8	830313-01	SPIRAL RETAINING RING	2
9	830100-01	SWi JAW - SOLD IN PAIRS	2
10	KIT 840140-01	RETAINING WASHER	4
11		M6 CSK HEX SCREW	1
12		WASHER (0.8MM)	2
13		M5 SCKT SET SCREW	1
14	KIT 840150-01	M6 GRUB SCREW	2
15		DECAL TI PUMP WRAP	1
16		DECAL WEDGE LRG	2
17		DECAL WEDGE SML	2
18	ON REQUEST	DECAL TI CYLINDER WRAP	1

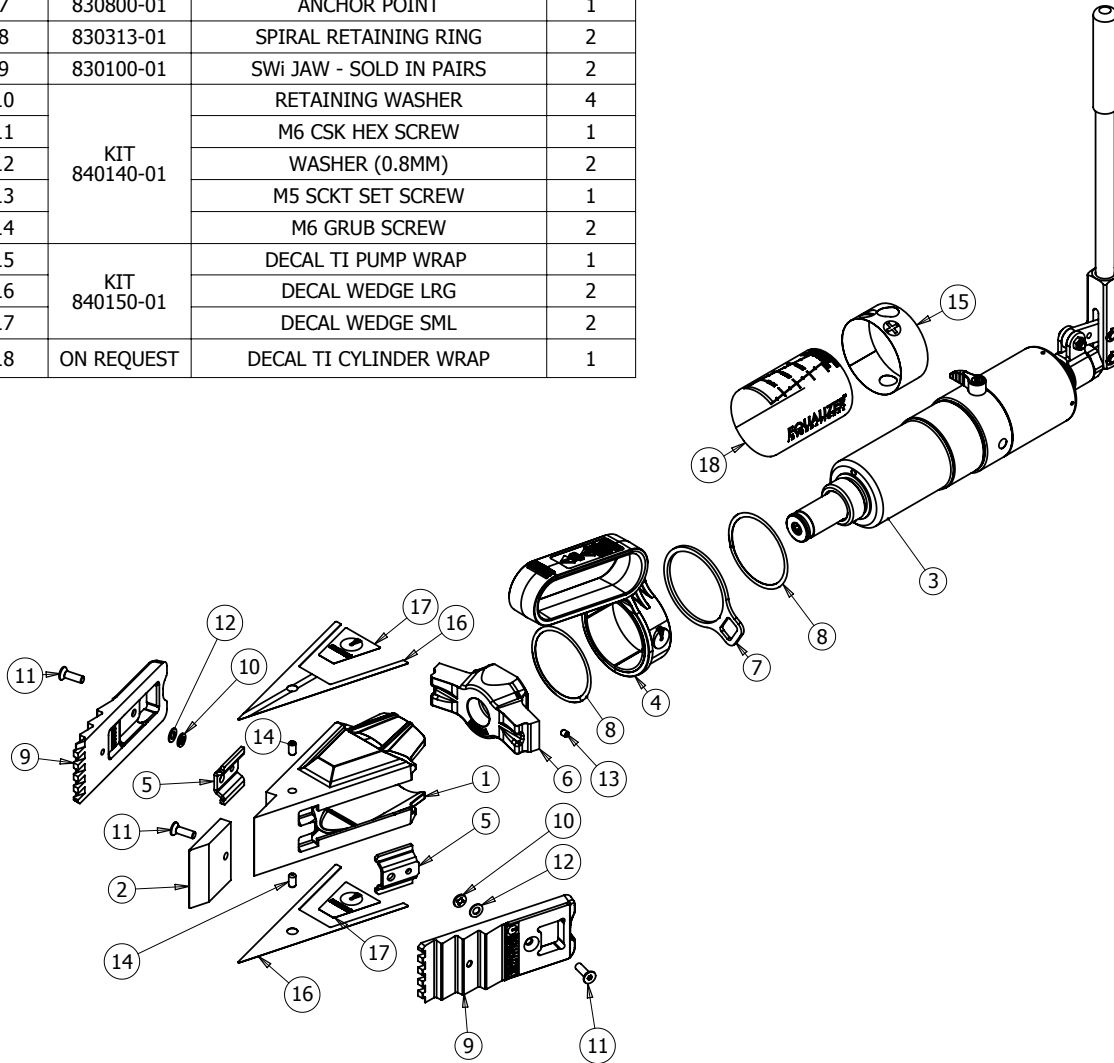

TI CYLINDER PARTS LIST

840300-01 REV.02

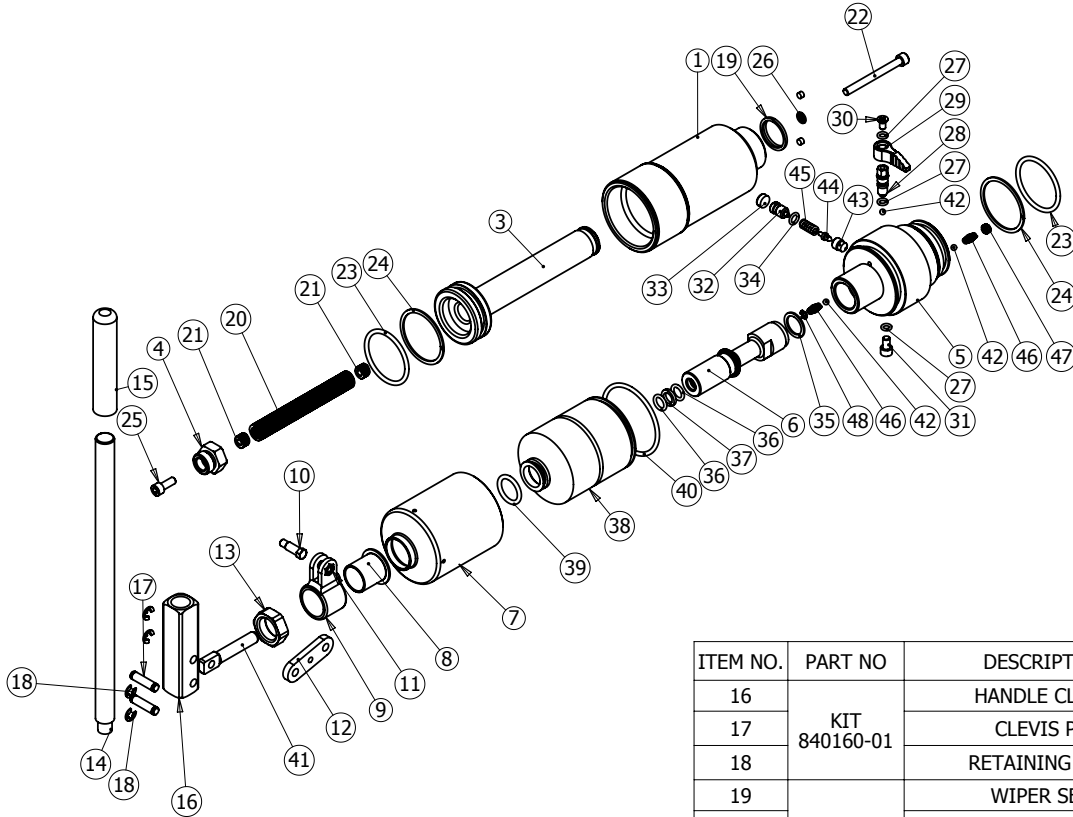

ITEM NO.	PART NO	DESCRIPTION	QTY.
1	830301-01	CYLINDER BODY	1
2	830310-01	CYL VENT PLUG	2
3	830302-01	PISTON	1
4	840100-01	NUT	1
5	840301-01	CYLINDER BASE	1
6	376901-01	PUMP PISTON HOUSING	1
7	840302-01	BLADDER HOUSING	1
8	372401-01	PISTON HOUSING CAP	1
9	372501-01	SWIVEL CLEVIS	1
10	373201-01	CLEVIS SCREW	1
11	373301-01	ANTI-LOOSEN NUT	1
12	373101-01	LINK CONNECTOR	1
13	372601-01	RETAINING NUT	1
14	373401-01	HANDLE ROD	1
15	306502-01	HANDLE GRIP	1

ITEM NO.	PART NO	DESCRIPTION	QTY.
16	KIT 840160-01	HANDLE CLEVIS	1
17		CLEVIS PIN	2
18		RETAINING RING	4
19	KIT 840110-01	WIPER SEAL	1
20		TENSION DIE SPRING	1
21		SPRING LOCK	2
22		M6 CAPSCREW	1
23		O-RING	2
24		BACK-UP RING	2
25	SCREW	1	
26	M6 GASKET SEAL	1	
27	KIT 840120-01	O-RING	3
28		RELIEF VALVE SCREW	1
29		RELIEF VALVE KNOB	1
30		FIXING SCREW	1
31		OIL FILL SCREW	1
32		OVERLOAD COVER SCREW	1
33		CAP	1
34		O-RING	1
35		WASHER	1
36		O-RING	2
37	BACK UP RING	1	
38	RESERVOIR BLADDER	1	
39	O-RING	1	
40	O-RING	1	
41	PUMP PISTON ROD	1	
42	STEEL BALL	1	
43	KIT 375020-01	STEEL BALL	2
44		CONE SEAT	1
45		CONE	1
46		LONG SEPARATOR SPRING	1
47		SPRING	2
48		SCREW	1
49		SPRING LOCK	1

SWi20/25TE PARTS LIST

830000-01 REV.02

ITEM NO.	PART NO	DESCRIPTION	QTY
1	830201-01	WEDGE	1
2	830202-01	WEDGE TIP	1
3	830300-01	HYDRAULIC CYLINDER - 10,000 PSI	1
4	830313-01	SPIRAL RETAINING RING	2
5	830400-01	HANDLE	1
6	830500-01	CAPTIVE FASTENER	2
7	830600-01	LUGS	1
8	830800-01	ANCHOR POINT	1
9	830100-01	SWi JAW - SOLD IN PAIRS	2
10	KIT 840140-01	RETAINING WASHER	4
11		M6 CSK HEX SCREW	2
12		WASHER (0.8MM)	6
13		M6 SCKT SET SCREW	1
14		M5 SCKT SET SCREW	4
15	KIT 840150-01	DECAL WEDGE LRG	2
16		DECAL WEDGE SML	2
17		DECAL TI PUMP (SURPLUS FOR TE & TM)	1
18	ON REQUEST	SW TE CYLINDER WRAP	1

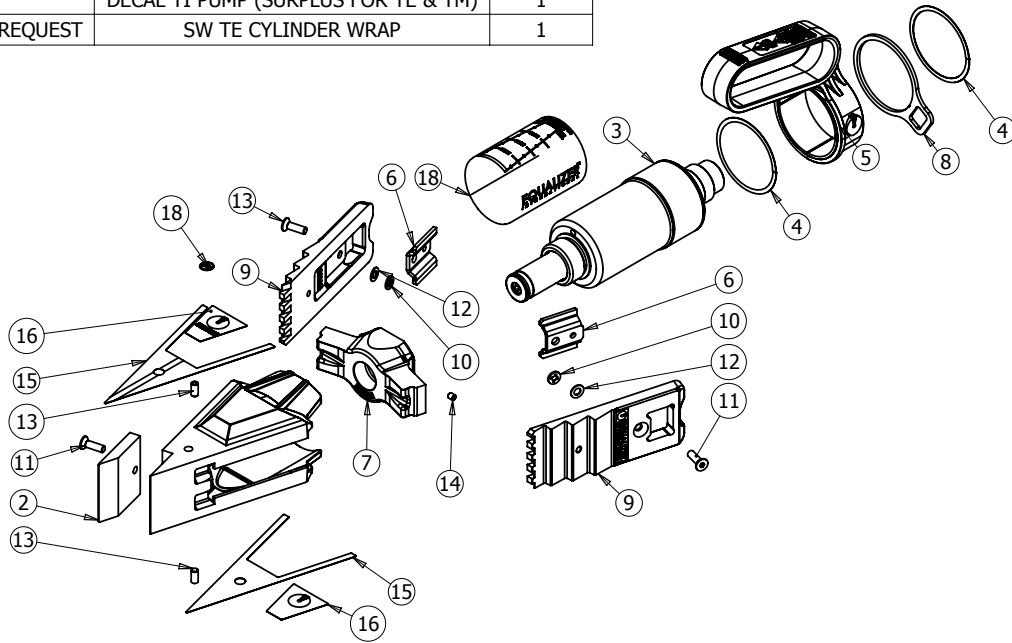

TE HYDRAULIC CYLINDER PARTS LIST

830300-01 REV.04

ITEM NO.	PART NO	DESCRIPTION	QTY
1	830301-01	CYLINDER BODY	1
2	830302-01	PISTON	1
3	830303-01	CYL END CAP	1
4	771110-01	3/8" NPT COUPLER 10kPSI	1
6	KIT 840110-01	WIPER SEAL	1
7		TENSION DIE SPRING	1
8		SPRING LOCK	2
9		M6 CAPSCREW	1
10		O-RING	2
11		BACK-UP RING	2
12		M6X25 SCKT H. SCREW	1
13		M6 GASKET SEAL	1

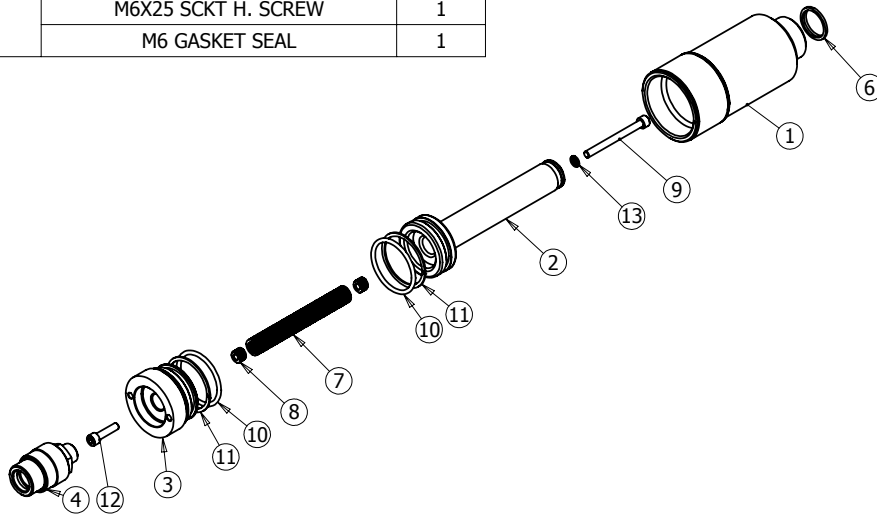

SAFETY BLOCK SMALL

830021-01 REV.02

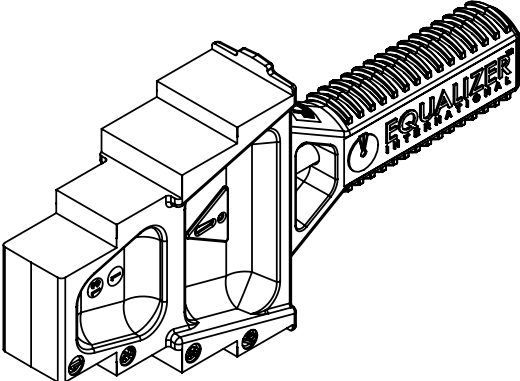

SAFETY BLOCK LARGE

830020-01 REV.02

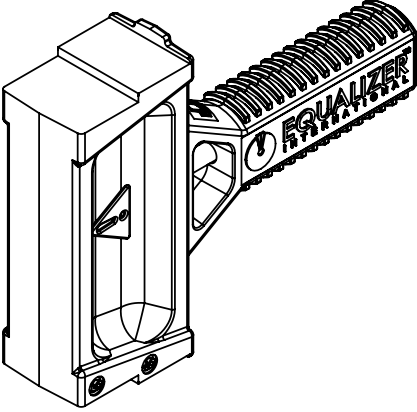

STEP BLOCK (PAIR)
830050-01 REV.02

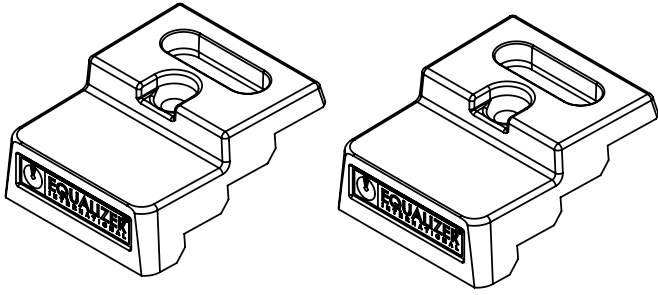

SAFETY BOND

830080-01 REV.01

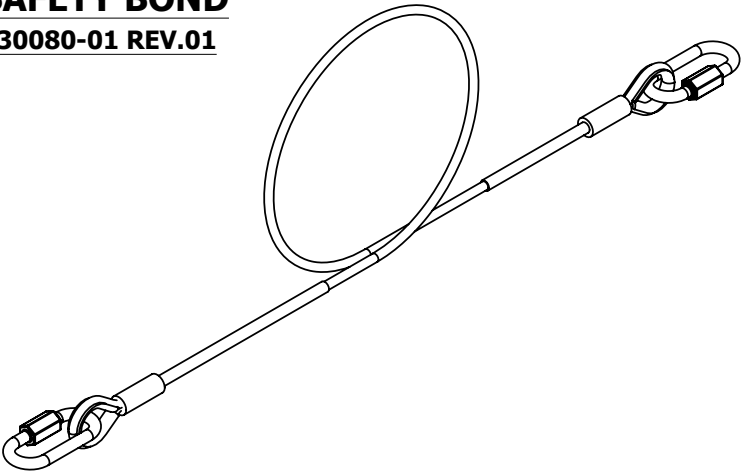

SWi FASTENER SERVICE KIT

840140-01 REV.01

ITEM NO.	DESCRIPTION	QTY.
1	RETAINING WASHER	4
2	M6 CSK HEX SCREW	5
3	WASHER (0.8MM)	2
4	M5 SCKT SET SCREW	1
5	M6 GRUB SCREW	2
6	M6 GRUB SCREW	2
7	4 MM ALLEN KEY	1

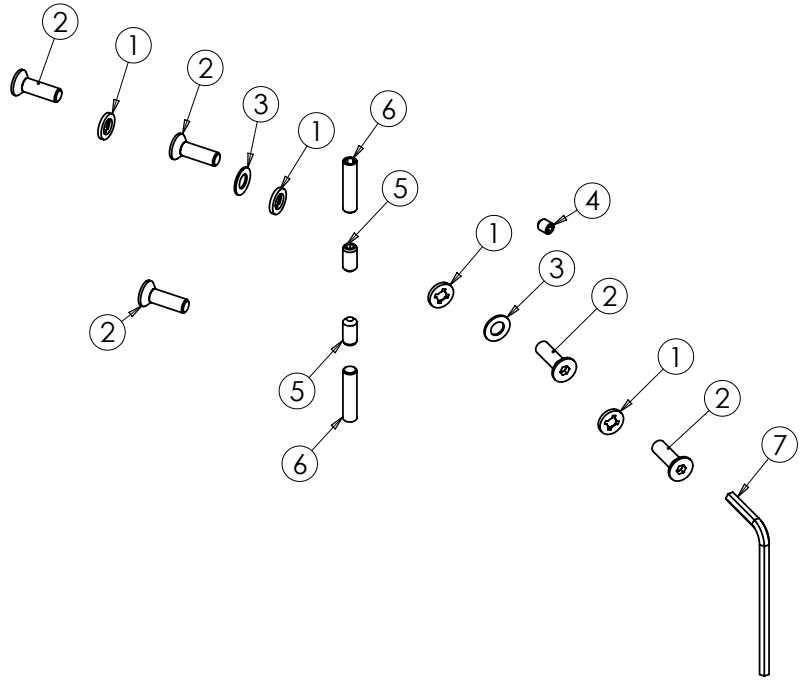

SWi DECAL SERVICE KIT

840150-01 REV.01

ITEM NO.	DESCRIPTION	QTY/ASS
1	DECAL TI PUMP WRAP	1
2	DECAL WEDGE SML	2
3	DECAL WEDGE LRG	2

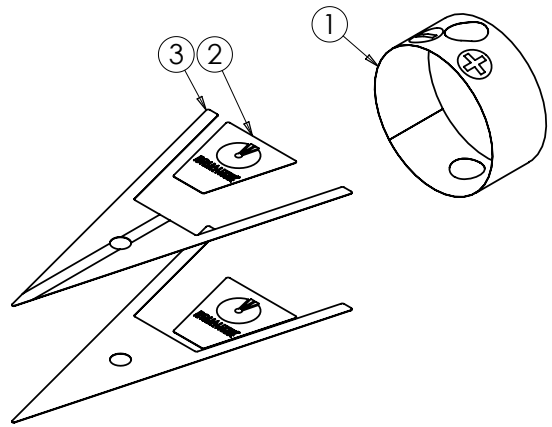

MECHANICAL CYLINDER SERVICE KIT

850110-01 REV.02

ITEM NO.	DESCRIPTION	QTY
1	THRUST WASHER	2
2	THRUST RACE	1
3	DOWEL PIN	1
4	M6 CSK HEX SCREW	1

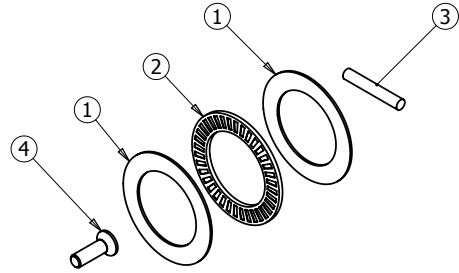

INTEGRAL BLADDER SERVICE KIT

840120-01 REV.02

ITEM NO.	DESCRIPTION	QTY.
1	STEEL BALL	1
2	O-RING	3
3	RELIEF VALVE SCREW	1
4	RELIEF VALVE KNOB	1
5	FIXING SCREW	1
6	OIL FILL SCREW	1
7	OVERLOAD COVER SCREW	1
8	CAP	1
9	O-RING	1
10	WASHER	1
11	O-RING	2
12	BACK UP RING	1
13	O-RING	1
14	PUMP PISTON ROD	1
15	RESERVOIR BLADDER	1
16	O-RING	1

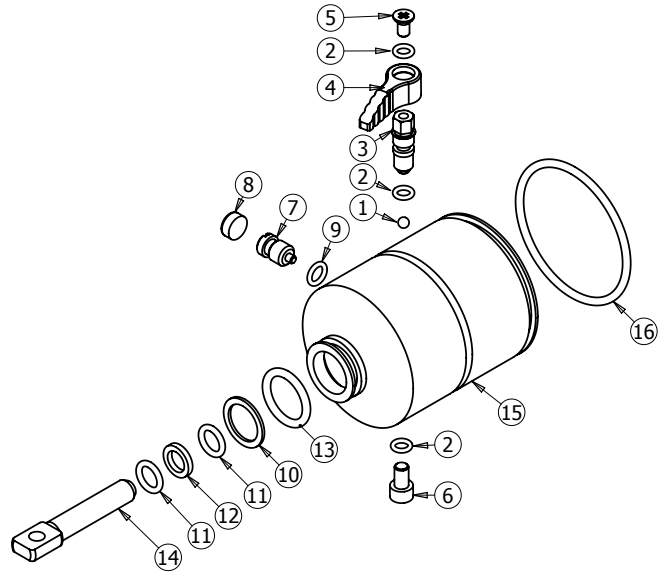

INTEGRAL MANIFOLD SERVICE KIT

840130-01 REV.03

ITEM NO.	DESCRIPTION	QTY.
1	STEEL BALL	2
2	CONE SEAT	1
3	CONE	1
4	LONG SEPARATOR SPRING	1
5	SPRING	2
6	SCREW	1
7	SPRING LOCK	1

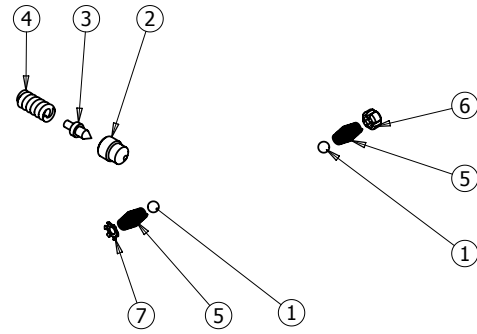

CLEVIS SERVICE KIT

840160-01 REV.01

ITEM NO.	DESCRIPTION	QTY
1	HANDLE CLEVIS	1
2	CLEVIS PIN	2
3	RETAINING RING	4

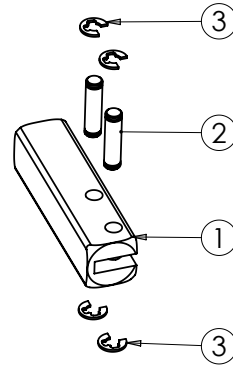

CYLINDER SERVICE KIT

840110-01 REV.02

ITEM NO.	DESCRIPTION	QTY.
1	WIPER SEAL	1
2	TENSION DIE SPRING	1
3	SPRING LOCK	2
4	M6 CAPSCREW	1
5	O-RING	2
6	BACK-UP RING	2
7	SCREW	1
8	M6 GASKET SEAL	1

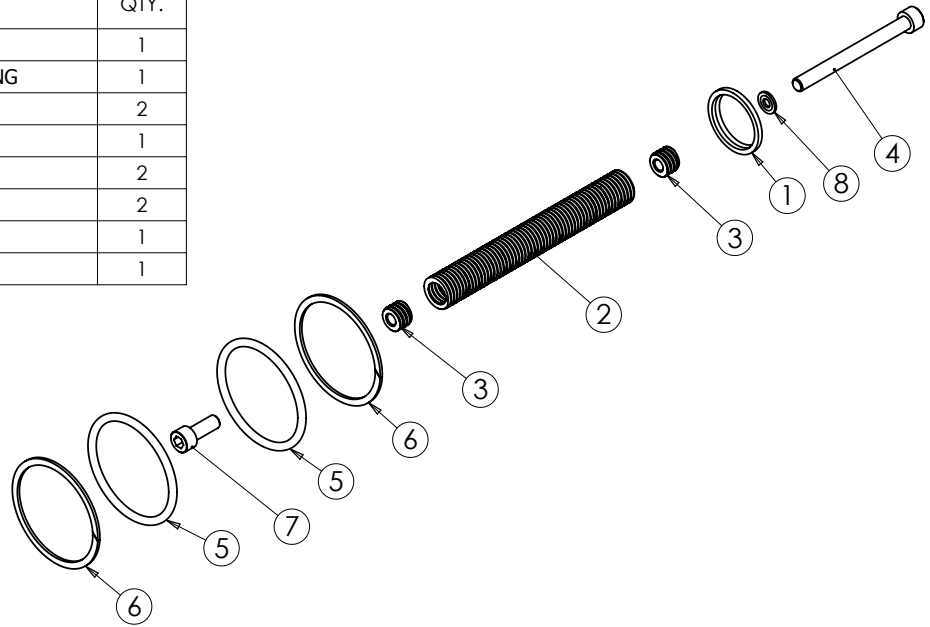



EQUALIZER INTERNATIONAL LTD.

Head Office
Equalizer House
Claymore Drive
Aberdeen
Scotland
UK
AB23 8GD
t: +44 (0) 1224 701970
f: +44 (0) 1224 823791

Houston Office
1330 Yale Street
Houston TX 77008
USA
t: +1 (713) 927-1840

www.equalizerinternational.com