

The tool handle can rotate 360° in relation to the Right Angle Gearbox allowing the most comfortable and safest position to be found

The handle and Right Angle Gearbox can index in relation to the tool gearbox meaning that reaction forces are not passed back to the operator

The Right Angle Gearbox can be purchased as a stand-alone product and retrofitted to existing Norbar tools by suitably qualified technicians

Norbar recommend tool recalibration after a Right Angle Gearbox has been fitted but where this is not possible, an efficiency of 97% can be assumed

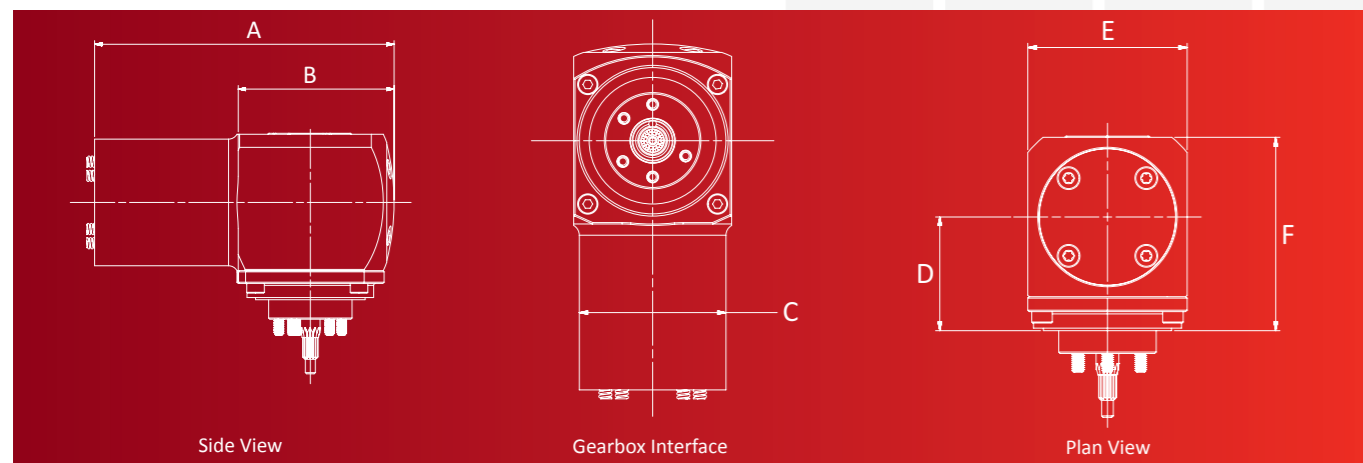

TECHNICAL SPECIFICATION							
PART NUMBER	DIMENSIONS (mm)						TOOL WEIGHT (kg)
	A	B	C	D	E	F	
180280	123	64	Ø52	40	56	68	2.2

GLOBAL SERVICE

Norbar is the only torque equipment manufacturer capable of offering tool and instrument calibration services to the original factory standard on four continents.

Accredited laboratories in Australia, USA, Singapore, China and India operate the same equipment and procedures as the UKAS accredited laboratory within our headquarters in the UK.

 NORBAR TORQUE TOOLS LTD
Wildmere Road, Banbury, Oxfordshire, OX16 3JU
UNITED KINGDOM
Tel + 44 (0)1295 753600
Email sales@norbar.com

 NORBAR TORQUE TOOLS
45-47 Raglan Avenue, Edwardstown
SA 5039
AUSTRALIA
Tel + 61 (0)8 8292 9777
Email enquiry@norbar.com.au

 NORBAR TORQUE TOOLS INC
36400 Biltmore Place, Willoughby
Ohio 44094
USA
Tel + 1 866 667 2272
Email inquiry@norbar.us

 NORBAR TORQUE TOOLS PTE LTD
194 Pandan Loop, #07-20 Pantech Business Hub
SINGAPORE 128383
Tel + 65 6841 1371
Email enquires@norbar.sg

 NORBAR TORQUE TOOLS (SHANGHAI) LTD
91 Building- 7F, No. 1122, North Qinzhou Road,
Xuhui District, Shanghai
CHINA 201103
Tel + 86 21 6145 0368
Email sales@norbar.com.cn







 NORBAR TORQUE TOOLS INDIA PVT. LTD
Plot No A – 168 Khairne Industrial Area
Thane Belapur Road
Mahape Navi Mumbai – 400 709
INDIA
Tel + 91 22 2778 8480
Email enquiry@norbar.in

www.norbar.com



Part number 07585 | Issue 1

NORBAR PRODUCT PORTFOLIO

-  Torque Screwdrivers
-  Torque Wrenches
-  Electronic Torque Wrenches
-  Manual Torque Multipliers
-  Pneumatic Torque Tools
-  Electronic Torque Tools
-  Torque Measurement Instruments
-  Torque Transducers
-  Ultrasonic Bolt Measurement
-  Calibration Services

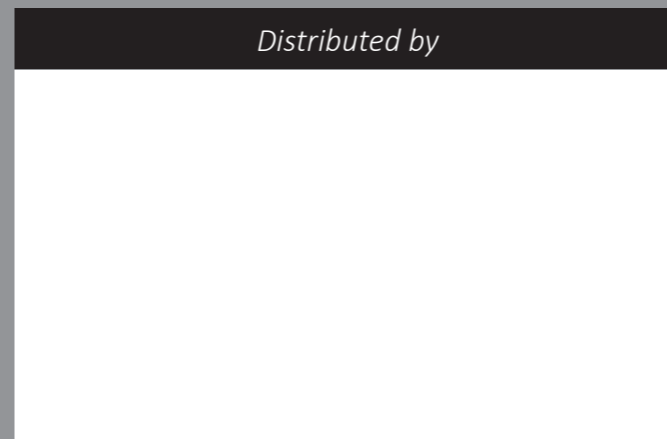

NEW

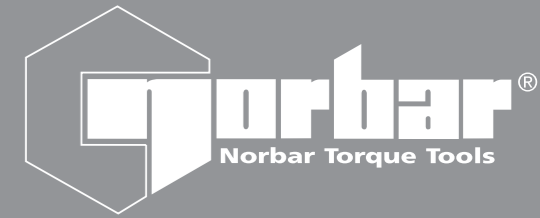

RIGHT ANGLE GEARBOX FOR APPLICATIONS WHERE ACCESS IS RESTRICTED

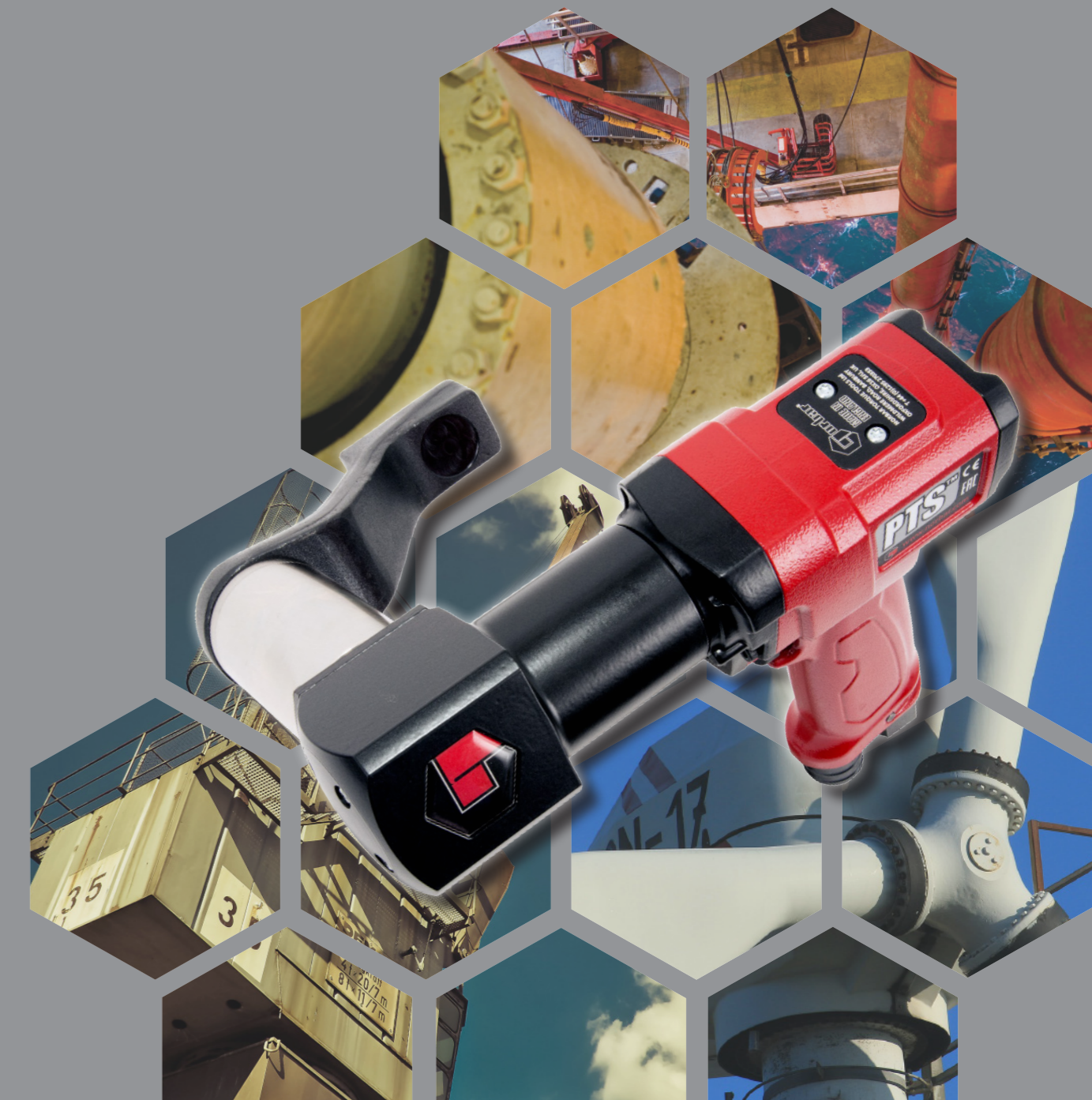

THE RIGHT ANGLE GEARBOX ENABLES THE BENEFITS OF NORBAR'S PNEUMATIC AND ELECTRIC TORQUE TOOLS TO BE BROUGHT TO A HOST OF APPLICATIONS FROM WHICH THEY ARE CURRENTLY EXCLUDED DUE TO SPACE LIMITATIONS



ET2 - 119 - 6000



PTM - 119 - 6000



PTS - 119 - 6000

Allows Norbar EvoTorque®, PneuTorque® PTM and PneuTorque® PTS™ tools to be used for many applications with restricted access

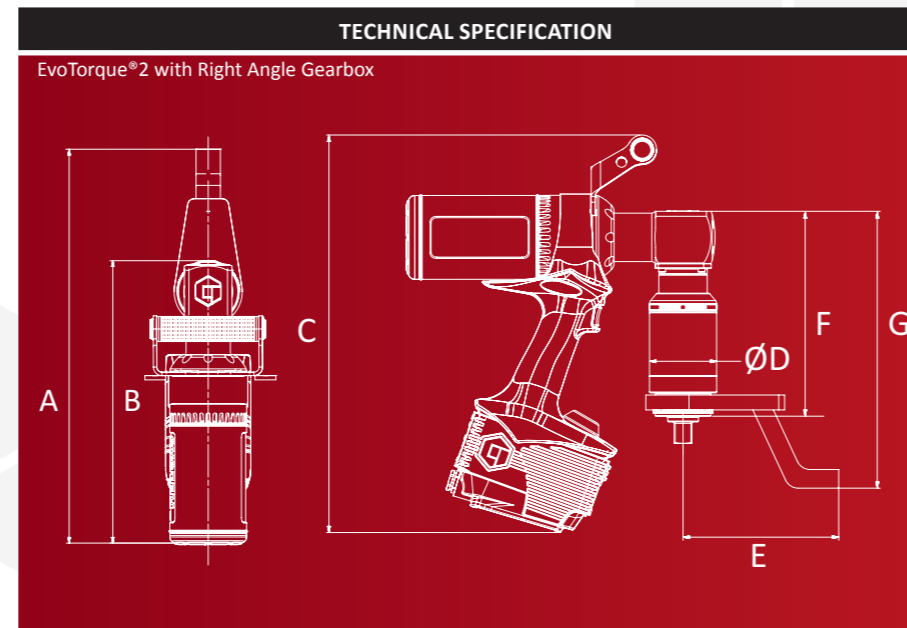

MODEL	ET2 - 72			ET2 - 92			ET2 - 119								
Part Number	180230.806.RA	180220.806.RA	180231.806.RA	180221.806.RA	180232.808.RA	180222.808.RA	180233.808.RA	180223.808.RA	180234.808.RA	180224.808.RA	180235.812.RA	180225.812.RA	180236.812.RA	180226.812.RA	
Voltage	110	230	110	230	110	230	110	230	110	230	110	230	110	230	
Square Drive	¾"			¾"			1"			1"			1½"		
Range	N-m			N-m			N-m			N-m			N-m		
	lbf-ft			lbf-ft			lbf-ft			lbf-ft			lbf-ft		
A (mm)	464	464	464	464	464	464	471	471	471	471	471	471	471	471	
B (mm)	331	331	331	331	331	331	331	331	331	331	331	331	331	331	
C (mm)	427	427	427	427	427	427	427	427	427	427	427	427	427	427	
D (mm)	Ø72	Ø72	Ø72	Ø72	Ø72	Ø72	Ø92	Ø92	Ø92	Ø92	Ø119	Ø119	Ø119	Ø119	
E (mm)	167	167	167	167	167	167	175	175	175	175	175	175	175	175	
F (mm)	220	220	253	253	271	271	295	295	295	295	368	368	368	368	
G (mm)	297	297	331	331	346	346	368	368	368	368	425	425	425	425	
Tool Weight (kg)	14.06	14.06	14.46	14.46	17.61	17.61	17.61	17.61	17.61	17.61	22.86	22.86	22.86	22.86	

Tool Weight includes the Right Angle Gearbox and Reaction Plate

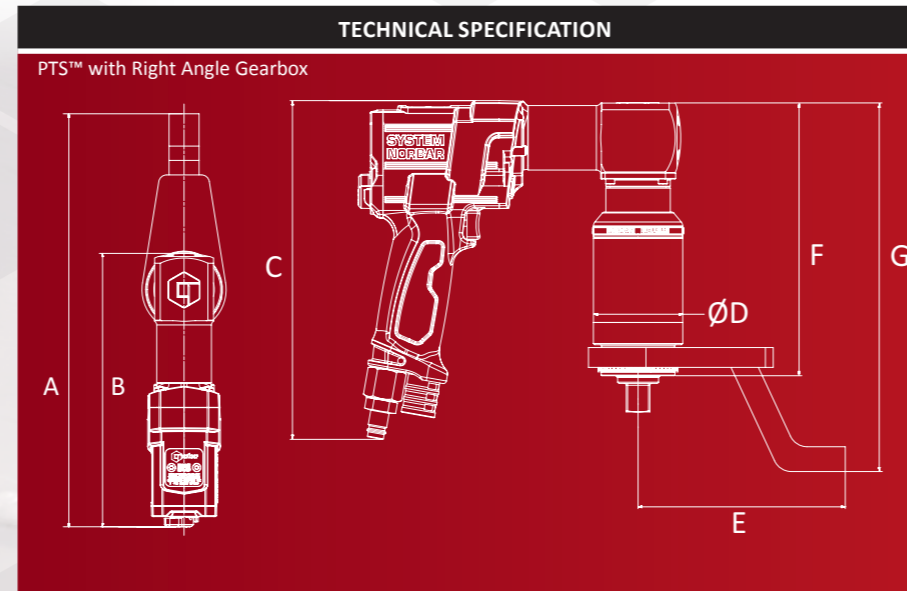

MODEL	PTS - 52		PTS - 72		PTS - 92		PTS - 119	
Part Number	180241.806.RA	180242.806.RA	180243.806.RA	180244.808.RA	180245.808.RA	180247.808.RA	180247.812.RA	180248.812.RA
Square Drive	¾"		¾"		1"		1½"	
Range	N-m		N-m		N-m		N-m	
	lbf-ft		lbf-ft		lbf-ft		lbf-ft	
A (mm)	357	357	393	393	393	400	400	400
B (mm)	260	260	260	260	260	260	260	260
C (mm)	273	273	273	273	273	273	273	273
D (mm)	Ø52	Ø52	Ø72	Ø72	Ø72	Ø92	Ø92	Ø119
E (mm)	131	131	167	167	167	175	175	175
F (mm)	193	193	220	220	253	271	271	295
G (mm)	253	253	297	297	331	346	346	368
Tool Weight (kg)	7.21	7.21	9.8	9.8	10.16	13.61	13.61	18.48

Tool Weight includes the Right Angle Gearbox and Reaction Plate

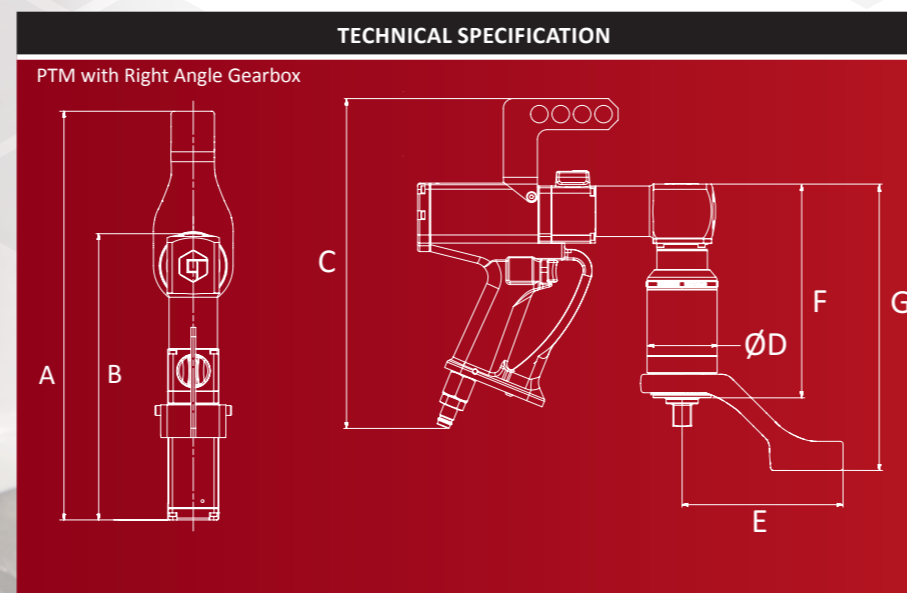

MODEL	PTM - 52		PTM - 72		PTM - 92			PTM - 119		
Part Number	18100.806.RA	18101.806.RA	18102.806.RA	18103.808.RA	18104.808.RA	18106.808.RA	18119.808.RA	18119.812.RA	18108.812.RA	18109.812.RA
Square Drive	¾"		¾"		1"		1"		1½"	
Range	N-m		N-m		N-m		N-m		N-m	
	lbf-ft		lbf-ft		lbf-ft		lbf-ft		lbf-ft	
A (mm)	403	403	438	438	438	477	477	471	471	
B (mm)	306	306	306	306	306	306	306	306	306	
C (mm)	339	339	339	339	339	339	339	339	339	
D (mm)	Ø52	Ø52	Ø72	Ø72	Ø72	Ø92	Ø92	Ø119	Ø119	
E (mm)	131	131	166	166	166	205	205	199	199	
F (mm)	193	193	220	220	253	271	271	295	295	
G (mm)	253	253	295	295	328	365	365	417	417	
Tool Weight (kg)	7.11	7.11	8.96	8.96	9.36	12.01	12.01	17.56	17.56	

PTM stall tools are also available as Forward Only tools, replace B with F when ordering

Tool Weight includes the Right Angle Gearbox and Reaction Plate



Allows more comfortable operation of these tools on vertical bolting applications at chest height and above as the pistol grip is presented correctly to the operator



Manufactured from steel, the Right Angle Gearbox is robustly constructed for durability and long life